

HEX DRIVE TORQUE WRENCH



Features

- The material used are Aluminium-Titanium alloy & High strength alloy steel for higher strength, intensity & durability.
- Deliver accurate (Accuracy $\pm 3\%$) performance in limited space.
- Anti-backlash mechanism for overcoming the back turn of the wrench.
- Optimised design that leads to compact & light weight tool.
- 360° x 180° Swivel mechanism.
- Wide range of hex sizes available for all applications.
- Used specified coating for aluminium power head which ensures better wear resistance of cylinder bore.
- Higher hardness of alloy steel reduces wear & tear between
- Ratchet and Pawl mechanism hence increases total life cycle of the tool.
- Leak proof quick connecting coupler.
- Piston seals used are with newly developed material for extended life cycle.

Optional Accessories:

- Long Extended Reaction Arm
- Square drive adapter kit
- Hex Reducers
- Stack Sockets/Insert Sockets

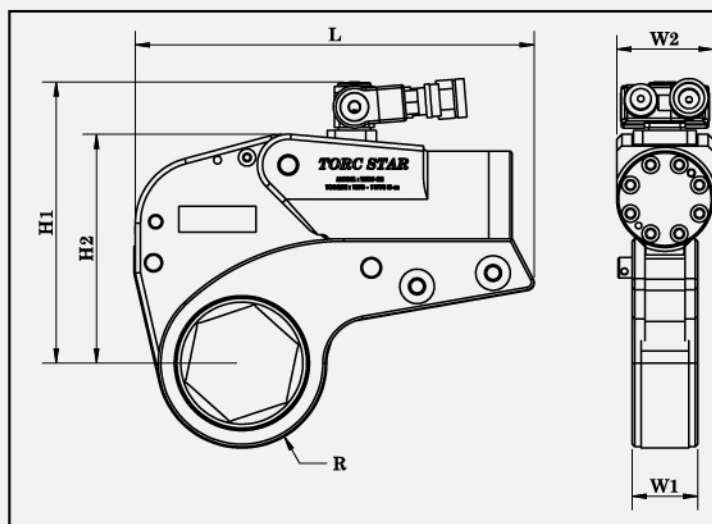

HEX DRIVE TYPE

MODEL NO.	UNITS	THTW-2H	THTW-6H	THTW-8H	THTW-20H	THTW-25H	THTW-45H
Torque Range	N-m	230 - 2410	580 - 6470	1090 - 11770	1850 - 18520	2307 - 23072	4180 - 44600
	Ft-Lbs	172 - 1935	400 - 4800	777 - 8726	1370 - 13722	1709 - 17090	3038 - 33038
Links (A/F)	mm	19 - 60	34 - 80	41 - 105	50 - 117	95 - 135	110 - 175
	Inch	3/4" - 2.3/8"	1.5/16" - 3.1/8"	1.5/8" - 4.1/8"	2 - 4.1/2"	3.3/4" - 4.1/2"	4.1/4" - 6.7/8"
Overall Length	mm	197	246	301	361	400	441
H1	mm	129	187	216	240	246	315
H2	mm	105	146	178	204	224	285
Width of link (W1)	mm	32	42	53	64	70	85
Width of cylinder (W2)	mm	51	66	83	99	110	131
Nose Radius (R)	mm	27 - 46	36 - 61	46 - 78	60 - 87	99	78 - 128
Power Head Wt.	kg	1	2	3.3	5.5	6.5	11.4
Link Wt.	kg	1.7	4.6	8.4	11.6	16.5	30

TORC STAR BOLTING TOOLS

✉ sales@torcstar.com 🌐 www.torcstar.com 📞 +91-22-49709846/47 📠 +91 9867344870

A-227, lodha supremus 2, Wagle estate, road no 22, thane -400604, Maharashtra India